

Your partner in inspection and quality control



metal detector

MFN11 + CONVEYOR 70





metal detector

MFN11 + CONVEYOR 70

Equipment

- | | |
|---|---|
| <ul style="list-style-type: none"> • Digital electronics with alphanumeric graphic display • 3 levels password access protection • Principle of operation: digital with bidimensional image • Working multifrequency • 100 storable product programs • 2 RS232 C serial ports • Phase adjustment function • Function and process alarm output • High immunity to environmental interferences • Positive fail safe | <ul style="list-style-type: none"> • Visualization of product image • Total printouts • Automatic balancing • Self-check function • OK pcs. and rejects totalizer • Report archive • Date/Time function • Automatic product compensation (Tracking) • Adjustable speed • In conformity with ISO - FDA - HACCP - GMP regulations • Production data management in conformity with the standards in force |
|---|---|

Accessories

- | | |
|--|--|
| <ul style="list-style-type: none"> • Products programs memory expansion • Ethernet interface • USB interface • Preset for network connection • Reject management systems • Signalling lamp | <ul style="list-style-type: none"> • FAT/SAT, IQ/OQ validations • Ejection synchronism photocell • Ejection check photocell • Separated electronic equipment • Wheels • Bin in stainless steel for rejected products |
|--|--|

Technical Specifications

MFN11 + Conveyor 70

Weighing range	from 0 up to 40000 g
Linear speed	up to 65 m/min
Pneumatic supply	0,6 Mpa
Power supply	230V 50/60Hz single phase
Power consumption	650 W
Mirror finishing of metal parts	Stainless Steel IP54 - IP65
Regulations	Conformity with CE regulations

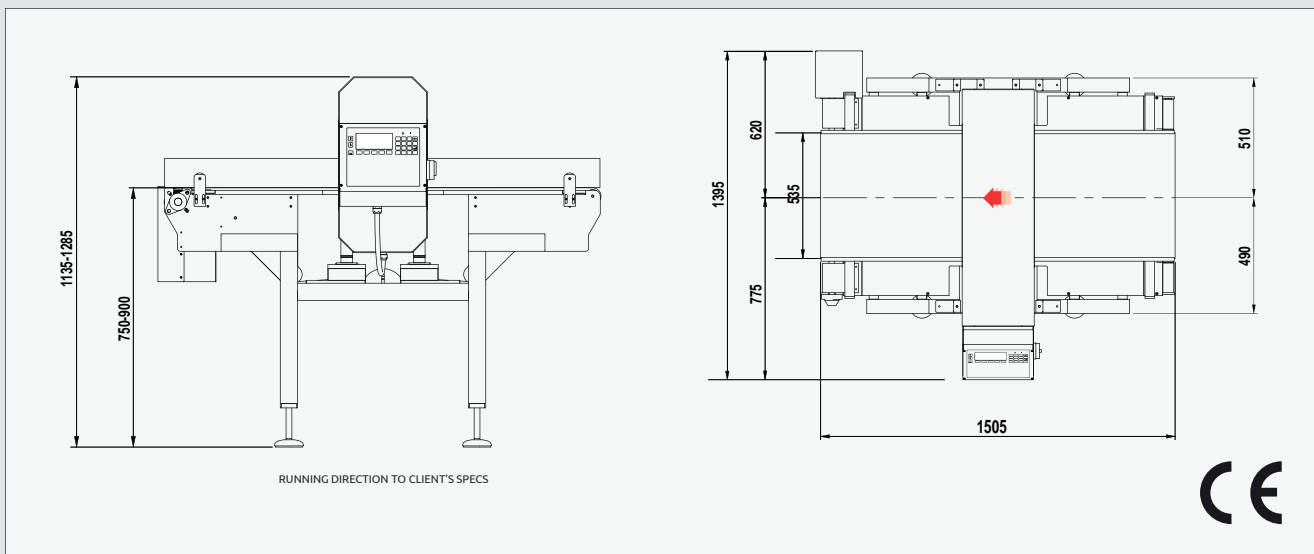

© PRISMA INDUSTRIALE S.r.l. cod. B0399



PRISMA INDUSTRIALE S.r.l.

Via La Bionda, 17 - 43036 Fidenza - Parma - Italy • Tel. +39 0524 527270 - Fax +39 0524 524142
www.prismaindustriale.com • info@prismaindustriale.com

Data appearing in this brochure may be modified without prior warning.
The machine illustrated in this document is full options.