

Your partner in inspection and quality control



checkweigher + metal detector

08D3 INTEGRATED COMPACT





PRISMA
*checkweigher +
 metal detector*
O8D3 Integrated Compact

Equipment

- Digital electronics with alphanumeric graphic display
- Electronic self-calibration device
- Production data management in conformity with the standards in force
- 3 levels password access protection
- Speed adjustable from keypad
- Mobile average function
- 100 storable product programs
- 1 RS232 serial port
- Conformity with standards ISO-FDA HACCP
- Principle of operation: digital with bidimensional image
- Phase adjustment function
- Function and process alarm output
- Automatic product compensation (tracking)
- Visualization of product image
- Self-check function
- Separated electronic equipment (optional)

Accessories

- Ejection systems
- Reject management systems
- Wind-prevention tunnel
- 24-columns panel printer
- Products programs memory expansion
- USB interface
- Ethernet interface
- Feed-back function
- Signalling lamp

Technical Specifications

O8D3 Integrated Compact

MID compatible

Weighing range	from 0 up to 2600 g	from 100 up to 1600 g
Display division	from 0,5 g	from 1,0 g
Linear speed	up to 100 m/min	up to 75 m/min
Throughput	up to 200 ppm	up to 200 ppm
Accuracy*	from $\pm 0,5$ g	from $\pm 0,5$ g
Pneumatic supply	0,6 Mpa	0,6 Mpa
Air consumption (for ejection)	1 NL	1 NL
Power supply	230V 50/60Hz single phase	230V 50/60Hz single phase
Power consumption	700 W	700 W
Mirror finishing of metal parts	Stainless steel IP55	Stainless steel IP55

*depending on the weight, dimensions and type of product

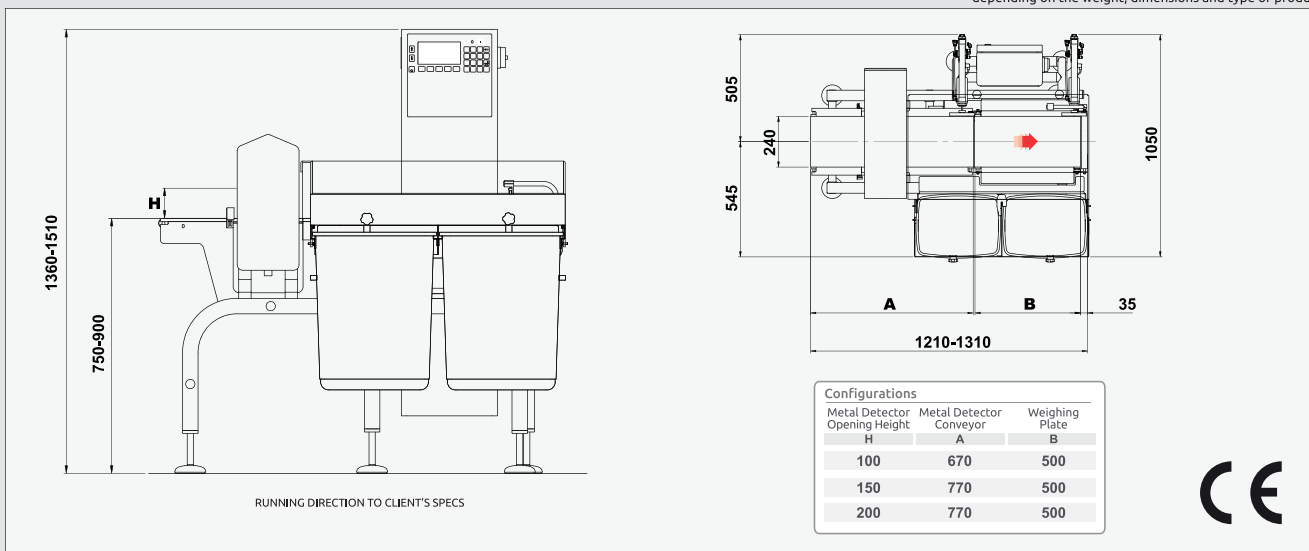

© PRISMA INDUSTRIALE S.r.l. cod. B0085



PRISMA INDUSTRIALE S.r.l.

Via La Bionda, 17 - 43036 Fidenza - Parma - Italy • Tel. +39 0524 527270 - Fax +39 0524 524142
 www.prismaindustriale.com • info@prismaindustriale.com

Data appearing in this brochure may be modified without prior warning.
 The machine illustrated in this document is full options.